



Band Oil Separator **DB65/115**

Bandwidth 55 or 115mm

PROBLEM



Lubricating oils pollute your fluids: by floating on the surface of the tanks, they create an anaerobic and nourishing environment that promotes the development of bacteria.

In addition to a **loss of efficiency**, the direct **consequences are an appearance of bad odors, a drop in the pH** as well as an instability of the product causing **skin risks for the operator**. Finally, a machine **oil change is necessary**.



Figure 2 : DB115-300 +
DKIT-08-01

YOUR OBJECTIVES



Figure 1 : DB65



- + Lifespan (Products & Tools)
- + Efficiency
- + Quality

- Bacteria
- Bad smells
- Irritations / Allergies
- Machine emptying



THE SOLUTION



The band oil separator is a simple and effective solution for removing foreign oils. It's easy to install and use.

Space-saving, it only requires a 230 VAC single-phase power supply (via a transformer) or directly 24 VDC (jack socket $\varnothing 5.5 * \varnothing 2.1$).

ADVANTAGES:

- ❖ **ROBUSTNESS** (Frame + stainless steel chute / Pulley on bearings)
- ❖ **DOUBLE SCRAPING** (on both sides of the band)
- ❖ **SIMPLIFIED MAINTENANCE** (Quick band change)
- ❖ **MULTIPLE MODELS**
- ❖ **AFTER-SALES SERVICE GUARANTEED** (1 year on all components *)
* Except wearing parts

OPTIONAL:

- ✓ Fixing magnets
- ✓ Mini decanter
- GUARANTEED EFFICIENCY**
- ✓ Specific bands (Ex: detergents)



- ON/OFF BUTTON
- MOTOR MORE ROBUST

- SPEED DRIVE + CONTROL SCREEN
- 230VAC OR 24VDC POWER SUPPLY

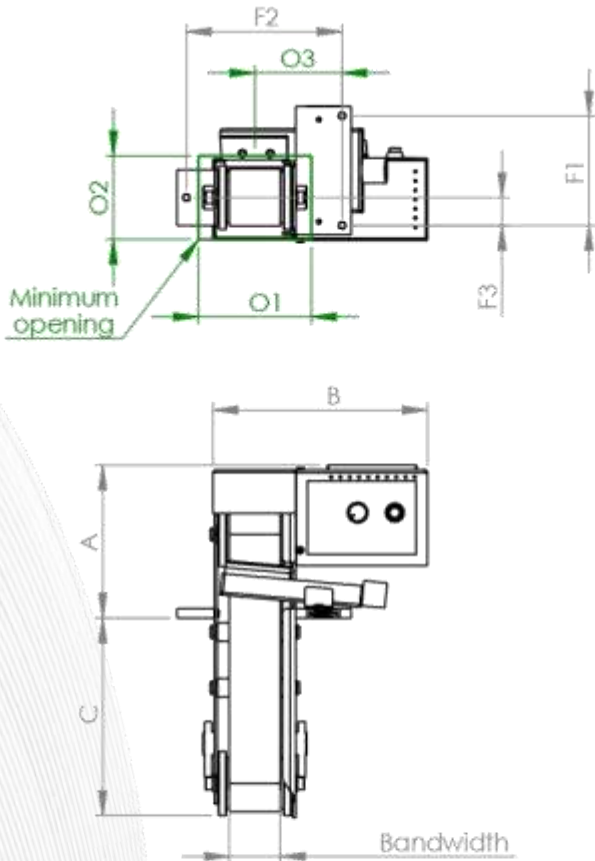

Some characteristics :

Power supply : 24VCC or 230VAC with the supplied transformer

Motor : 24VCC / 13W / IP40

Evacuation : Tube Ø26.9mm outside

Optional :

Model	Magnet for vertical side	Magnet for horizontale side	Decanter
DB65-200	DKIT-03-04	DKIT-03-04	DKIT-08-01
DB65-300			
DB65-500			
DB65-1000	DKIT-03-01		
DB115-200			
DB115-300			
DB115-500			
DB115-1000	DKIT-03-01		

Model	Bandwidth	A	B	C	F1	F2	F3	O1	O2	O3	
DB65-200	55	165	229	210	118	167	30	125	95	94	
DB65-300				315							
DB65-500				500							
DB65-1000				1005							
DB115-200	115		289	289		215		227	185	95	124
DB115-300						315					
DB115-500		500									
DB115-1000		1005									

